

REV	ECN NO.	DATE

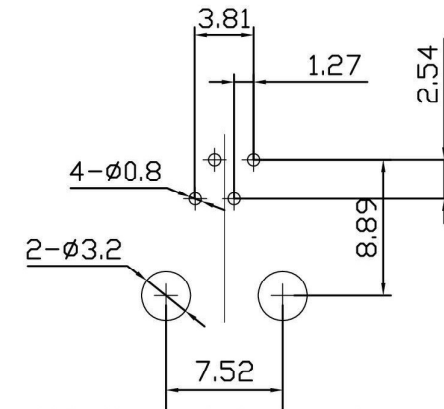
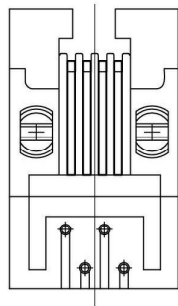
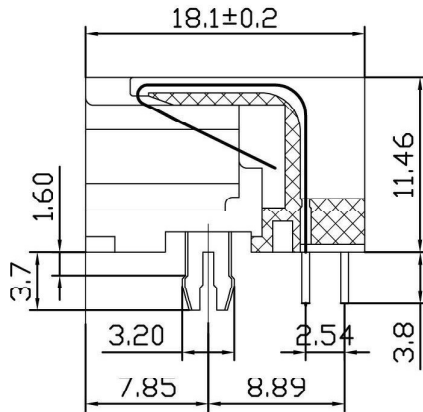
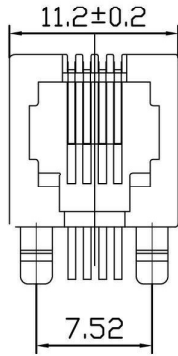

PC Board Layout
Component Side Shown

NOTES:

MATERIAL

- 1. HOUSING MATERIAL : GLASS FILLED POLYESTER UL94V-0.
- 2. CONTACT MATERIAL : PHOSPHOR BRONZE ∅0.45mm.
- 3. PLATING : GOLD PLATING OVER NICKEL.
FU', 3U', 6U', 15U', 30U', 50U'

ELECTRICAL:

- 1. VOLTAGE RATING : 125 VAC RMS.
- 2. CURRENT RATING : 1.5 AMP.
- 3. CONTACT RESISTANCE : 30 MILLIOHMS MAX.
- 4. INSULATION RESISTANCE : 500 MEGOHMS MIN @ 500V DC .
- 5. DIELECTRIC WITHSTANDING RESISTANCE : 1000V AC RMS 50Hz. 1MIN.

MECHANICAL:

- 1. DURRABILITY : 750 CYCLES MIN.
- 2. PCB RETENTION PRE-SOLDER : 1 LB MIN.

ENVIRONMENTAL:

- 1. STORAGE : -40°C TO 85°C.
- 2. OPERATION : 0°C TO 70°C.

RoHS Compliant

TOLERANCES		DATE		Ho Chien www.hochien.com			
mm							
.0± 0.30	±			FINISH		RJ11 JACK	
.00± 0.25	±			SCALE		PART NO.	
.000± 0.10	±			1:1	UNIT	TM-53A4411S	
ANGLES	± 1°			mm		SIZE	
THIRD ANGLE PROJECTION		Designed		Checked		A4	
						01	Approved
						SHEET OF	