

SIDE A

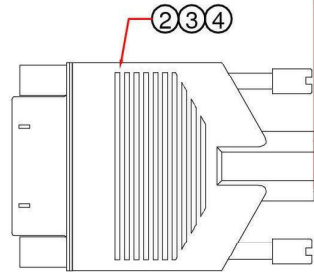

Length

SIDE B

WIRE LIST					
<u>SIDE A</u>		<u>SIDE B</u>			
1	Black	Open	14	Brown/White	Open
2	Brown	Open	15	Red/White	Open
3	Red	Open	16	Orange/White	Open
4	Orange	Open	17	Green/White	Open
5	Yellow	Open	18	Blue/White	Open
6	Green	Open	19	Purple/White	Open
7	Blue	Open	20	Red/Black	Open
8	Purple	Open	21	Orange/Black	Open
9	Gray	Open	22	Yellow/Black	Open
10	White	Open	23	Green/Black	Open
11	Pink	Open	24	Gray/Black	Open
12	Light Green	Open	25	Pink/Black	Open
13	Black/White	Open	SHELL	Braid+Drain wire	Open

ORTHER WIER COLOR:PINK/RED CUT

PART NUMBERS	LENGTH
CA-U0213-0001	457 ± 15MM
CA-U0213-0002	914 ± 20MM
CA-U0213-0003	1000 ± 20MM

1. ELECTRICAL CHARACTER:

- a. 100 % OPEN&SHORT TESTING
- b. WITHSTANDING VOLTAGE:DC 300V 0.1Sec
- c. INSULATION RESISTANCE:20M Ohms(Min)
- d. CONDUCTIVE RESISTANCE:2 Ohms(Max)

2.PACKAGING:

1PCS/POLY BAG +LABEL

3.THE ASSEMBLY REQUIREMENTS TO BE COMPLY WITH LATEST IPC/WHMA-A-620 STANDARD

④	COPPER FOIL	COPPER FOIL W=8mm L=25mm	2PCS
③	TERMINAL	MICRO-D FEMALE CONTACT PHOSPHOR BRONZE PLATED GOLD 15u" CRIMP TYPE	25PCS
②	CONNECTOR	MICRO-D 25P FEMALE CRIMP TYPE WITH ASSEMBLY HOOD W/THUMBSCREWS	1SET
①	CABLE	UL2464 #28AWG*13P+AEB(85%) OD:8.0mm BLACK PVC JACKET	1PCS
NO	PART NAME	SPECIFICATION	Q'TY

REV.	DESCRIPTION	DATE	APPVL. BY	ECO(N) NO.
A0				
UNIT	MM	XX. X.X	DRAW. BY	
SCALE	NONE	TOLERANCE	CHECKED	
SHEET	1/1	ANGLE ±0.5°	APPVL. BY	

Ho Chien
www.hochien.com

DWG
NAME

**25P MICRO-D FEMALE
W/ UL 2464 AWG CABLE**

DWG NO.

P/N NO.

SEE TABLE

ITEM	DESCRIPTION		MATERIAL	FINISH	Q'TY
①	MICRO-D FEMALE 25P UPPER INSULATOR /	P/N: R-HS-012025-S1-1	THERMOPLASTIC	_____	1
②	MICRO-D FEMALE 25P UPPER INSULATOR	P/N: R-HS-012025-S1-2	THERMOPLASTIC	_____	1
③	MICRO-D FEMALE 25P Lower Shield	P/N: R-HS-012025-S1-3	STEEL	TIN PLATED	1
④	MICRO-D FEMALE 25P UPPER SHIELD	P/N: R-HS-012025-S1-4	STEEL	TIN PLATED	1
⑤	MICRO-D P FEMALE BACKSHELL	P/N: R-HS-012025-S1-6	THERMOPLASTIC	_____	1
⑥	MICRO-D FEMALE CONTACT	P/N: R-TM-01202S-13S	PHOSPHOR BRONZE	GOLD	25
⑦	JACKSCREWS	P/N: R-SF-012009-01	STEEL	NICKEL	2

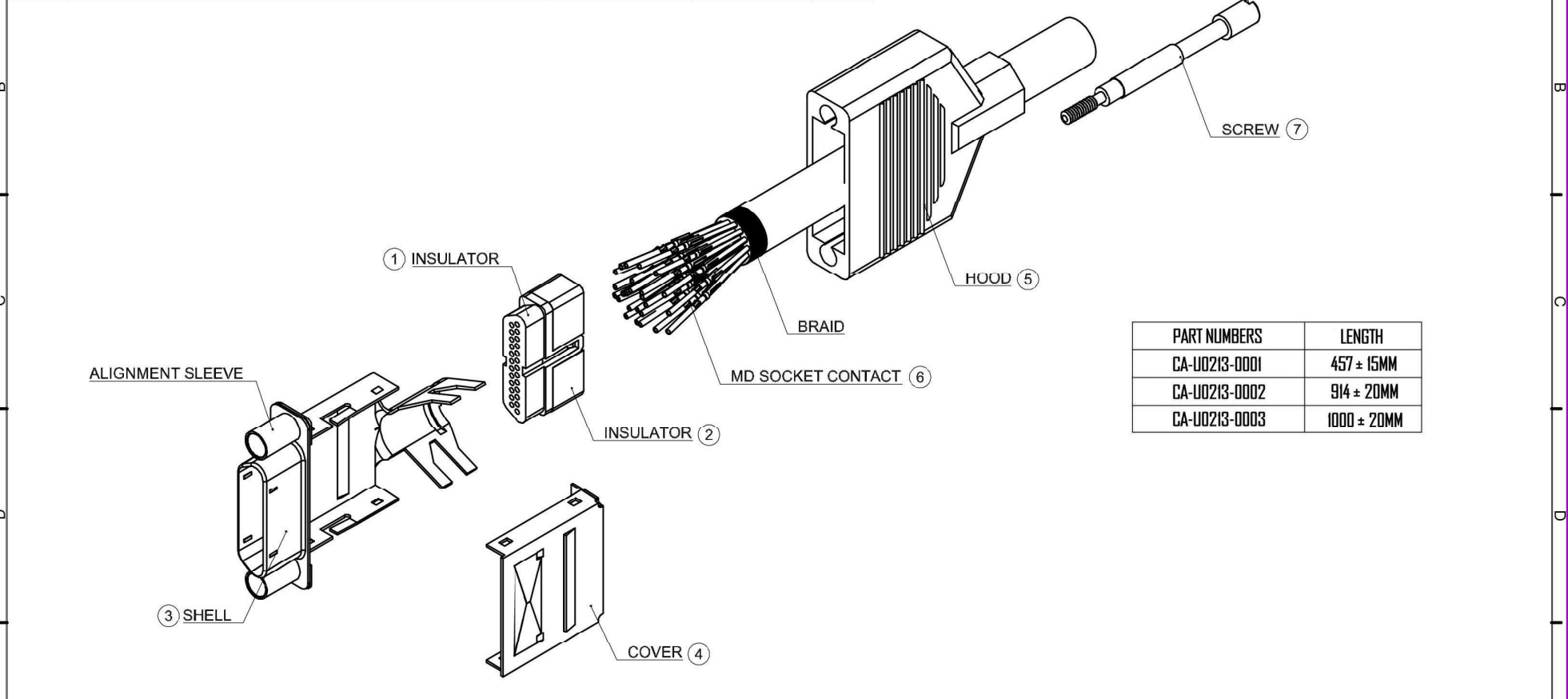

A0					
REV.	DESCRIPTION		DATE	APPVL. BY	ECO(N) NO.
UNIT	MM		XX. X.X X.XX	DRAW. BY	
SCALE	NONE			TOLERANCE	CHECKED
SHEET	1 / 1		ANGLE ±0.5°	APPVL. BY	

 www.hochien.com	DWG NAME	25P MICRO-D FEMALE	DWG NO.
		W/ UL 2464 AWG CABLE	SEE TABLE