

# Tantalum Capacitor ( SCS Series )



The product is smaller version of the SCN series products.

The SCS series have fully molded, compliant leadframe construction designed for use in applications utilizing solder (Reflow, Wave ), conductive adhesive or thermal compression bonding techniques.

## General Features

Miniaturized tantalum chip capacitors with extended capacitance.

(Reduced size 1/2 to 1/3 in comparison with SCN.)

- Molded Case available in five case codes.
- Compatible with automatic pick and place equipment.
- Meets or Exceeds EIA standard 535BAAC .
- Extended Range Values
- Terminations: 100 % Sn , RoHS compliant.

## Applications

- General electronic equipment
- Smoothing Circuit of DC-DC Converters & Output side of AC-DC Converters
- De-Coupling Circuit of High Speed ICs & MPUs
- Various Other High Frequency Circuit Applications

## Part Numbering

<u>TC</u>	<u>SCS</u>	<u>0J</u>	<u>106</u>	<u>M</u>	<u>B</u>	<u>A</u>	<u>R</u>	0
①	②	③	④	⑤	⑥	⑦	⑧	

① Abbreviation of Tantalum Capacitor

② Type of Series

③ Rated Voltage

④ Capacitance Tolerance

⑤ Capacitance Tolerance

⑥ Case size

⑦ Packing

⑧ Packing Polarity

## ① ABBRIVIATION OF TANTALUM CAPACITOR

## ② TYPE OF SERIES

The symbol shows the type of the capacitor.

**SCS** : Samsung environmental Capacitor **S**tandard series

## ③ RATED VOLTAGE

Symbol	DC Rated Voltage	Symbol	DC Rated Voltage
0E	2.5	1C	16
0G	4	1D	20
0J	6.3	1E	25
1A	10	1V	35

## ④ CAPACITANCE

Symbol	Capacitance ( $\mu\text{F}$ )	Pico Farad (pF)	Symbol	Capacitance ( $\mu\text{F}$ )	PicoFarad (pF)
105	1.0	$10 \times 10^5$	684	0.68	$68 \times 10^4$
106	10.0	$10 \times 10^6$	475	4.7	$47 \times 10^5$

## ⑤ CAPACITANCE TOLERANCE

Symbol	Tolerance(%)	Symbol	Tolerance(%)
K	$\pm 10$	M	$\pm 20$

## ⑥ CASE SIZE

Case	EIA Code	Case	EIA Code
J	1608	C	6032
P	2012	D	7343
A	3216		
B	3528		

## 7 PACKING

Symbol	Packing Code
A	7 inch
C	13 inch

## 8 PACKING POLARITY

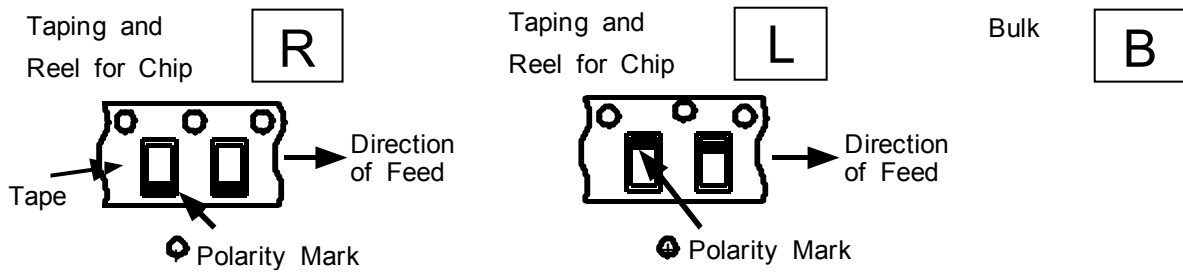

## APPEARANCE AND DIMENSION

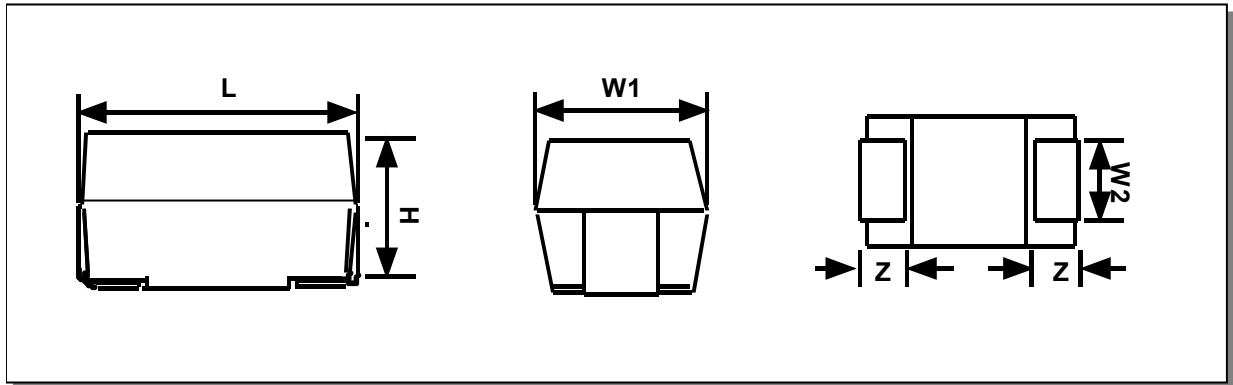

Code	EIA Code	DIMENSION (mm)				
		L	$W_1$	$W_2$	H	Z
P	2012	$2.0 \pm 0.2$	$1.25 \pm 0.2$	$0.9 \pm 0.1$	1.2 MAX	$0.5 \pm 0.2$
A	3216	$3.2 \pm 0.2$	$1.6 \pm 0.2$	$1.2 \pm 0.1$	$1.6 \pm 0.2$	$0.8 \pm 0.3$
B	3528	$3.5 \pm 0.2$	$2.8 \pm 0.2$	$2.2 \pm 0.1$	$1.9 \pm 0.2$	$0.8 \pm 0.3$
C	6032	$6.0 \pm 0.3$	$3.2 \pm 0.3$	$2.2 \pm 0.1$	$2.5 \pm 0.3$	$1.3 \pm 0.3$
D	7343	$7.3 \pm 0.3$	$4.3 \pm 0.3$	$2.4 \pm 0.1$	$2.8 \pm 0.3$	$1.3 \pm 0.3$

## CHARACTERISTIC LINE UP

### ⑦ CHARACTERISTIC MAP

#### ● Capacitance Range

RATED VOLTAGE	Size	Capacitance Range (nF)				
		100	1000	10000	100000	1000000
2.5V	B (3528)				22000	
4V	P (2012)			22000		
	A (3216)			47000		
	B (3528)			100000		
	C (6032)			220000		
	D (7343)			470000		
6.3V/7V	P (2012)			22000		
	A (3216)			47000		
	B (3528)			100000		
	C (6032)			220000		
	D (7343)			470000		
10V	P (2012)			10000		
	A (3216)			22000		
	B (3528)			47000		
	C (6032)			100000		
	D (7343)			220000		
16V	P (2012)			2200		
	A (3216)			22000		
	B (3528)			22000		
	C (6032)			68000		
	D (7343)			100000		
20V	P (2012)			680		
	A (3216)			4700		
	B (3528)			10000		
	C (6032)			33000		
	D (7343)			100000		
25V	A (3216)			2200		
	B (3528)			6800		
	C (6032)			22000		
	D (7343)			33000		
35V	A (3216)			1500		
	B (3528)			3300		
	C (6032)			10000		
	D (7343)			22000		

● Standard value and Case size

Miniaturized Tantalum Chip Capacitor with Extended Capacitance Range

STANDARD VALUE AND CASE SIZE

	W.V	2.5V	4V	6.3V	10V	16V	20V	25V	35V
Cap.( $\mu$ F)		(0E)	(0G)	(0J)	(1A)	(1C)	(1D)	(1E)	(1V)
0.22	224		P	P	P	P			
0.33	334								
0.47	474		P	P	P	P	P		A
0.68	684		P	P	P	P	P	A	A
1	105		P	P	P	P	A	A	A
1.5	155					A	A	A	A,B
2.2	225		P	P	P,A	<b>NEW</b> P,A	A	A,B	B
3.3	335		P	P,A	P,A	A	A,B	B	B
4.7	475		P,A	P,A	P,A	(P),A,B	A,B	B	C
6.8	685		P,A	P,A	A,B	A,B	B	B,C	C
10	106		P,A	P,A,B	P,A,B	A,B	B,C	<b>NEW</b> B,C	C,D
15	156		A,B	A,B	A,B	B,C	C	C,D	<b>NEW</b> C,D
22	226		P,A,B	P,A,B	A,B,C	B,C	<b>NEW</b> B,C,D	C,D,E	D
33	336		A,B	A,B,C	A,B,C	(B),C,D	C,D	D,E	(D)
47	476		A,B,C	A,B,C	B,C,D	C,D	D		
68	686		B,C	B,C,D	(B),C,D	C,D	D		
100	107		B,C,D	B,C,D	C,D	D	<b>NEW</b> D		
150	157		C,D	C,D	D	(D)			
220	227	B	C,D	C,D	D				
330	330		D	D	(D)				
470	477		D	D					
680	687		(D)						

( )Under Development

New products (2005.01~) are shown in blue.

Environmentally friendly tantalum chip capacitors with lead-free terminal/Conform to RoHS

## RELIABILITY TEST CONDITION

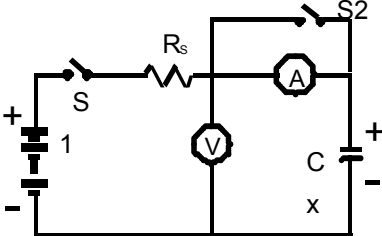
NO	ITEMS	TEST CONDITION	PERFORMANCE
1	RATED DC VOLTAGE	-55°C ~ +85°C	2.5 ~ 35V
2	CAPACITANCE	MEASURING FREQUENCY : 120±12Hz MEASURING VOLTAGE : 0.5Vrms + 0.5~2V DC MEASURING CIRCUITS : EQUIVALENT SERIES CIRCUIT	CAPACITANCE RANGE 0.1 ~ 330µF TOLERANCE ON CAP. ±10%, ±20%
3	TANGENT OF LOSS ANGLE	MEASUREMENT SHALL BE MADE UNDER THE SAME CONDITIONS AS THOSE GIVEN FOR THE MEASUREMENT OF CAPACITANCE.	
4	LEAKAGE CURRENT	<p>THE RATED DC VOLTAGE SHALL BE APPLIED TO TERMINALS ACROSS THE TEST CAPACITOR C<sub>x</sub>, BY THE METHOD AS SHOWN BELOW. THE LEAKAGE CURRENT SHALL THEN BE MEASURED AFTER CHARGE FOR 5 MIN.</p> <p style="text-align: center;"><u>MEASURING CIRCUITS</u></p>  <p>WHERE R<sub>s</sub> : STANDARD RESISTOR(PROTECTIVE R :1KΩ) Ⓥ : DC VOLTMETER OR ELECTRONIC VOLTMETER S1 : DC POWER SUPPLY SWITCH S2 : PROTECTIVE SWITCH FOR A AMMETER C<sub>x</sub> : TEST CAPACITOR ⓐ : DC AM-METER FOR LEAKAGE CURRENT</p>	0.01CV or 0.5µA WHICHEVER IS GREATER
5	IMPEDENCE	<p>AC VOLTAGE(0.5Vrms OR LESS) OF A FREQUENCY SPECIFIED ON NEXT PAGE SHALL BE APPLIED AND THE VOLTAGE DROP ACROSS CAPACITOR TERMINALS SHALL BE MEASURED</p> <p>THE IMPEDANCE SHALL BE CALCULATED BY THE FOLLOWING EQUATION.</p> $\text{Impedance} Z  = \frac{E}{I}$ <p>WHERE E : VOLTAGE DROP ACROSS THE CAPACITOR TERMINALS I : CURRENT FLOWING THROUGH THE CAPACITOR (FREQUENCY : 100±10kHz)</p>	

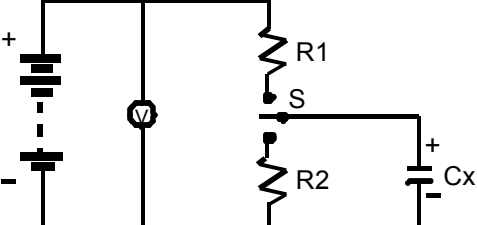
NO	ITEMS	TEST CONDITION	PERFORMANCE							
6	TEMPERATURE STABILITY	THE CAPACITOR SHALL BE SUBJECTED IN TURN TO PROCEDURES SPECIFIED BELOW								
		STEP	TEMP.	DURATION	CHANGE IN CAPACITANCE ( ΔC )	TANGENT OF LOSS ANGLE (D.F.)	LEAKAGE CURRENT			
		1	25±2°C		WITHIN SPECIFIED TOLERANCE	TABLE 1 ON PAGE 13	WITHIN ORIGINAL LIMIT			
		2	-55 <sup>0</sup> <sub>-3</sub> °C	2 HOURS.	- 10 TO 0% OF INITIAL VALUE	TABLE 1 ON PAGE 13	N/A			
		3	25±2°C	25 MIN.						
		4	+85 <sup>+3</sup> <sub>0</sub> °C	2 HOURS.	0 TO +10% OF INITIAL VALUE	TABLE 1 ON PAGE 13	WITHIN 10X ORIGINAL LIMIT			
		5	+125 <sup>+3</sup> <sub>0</sub> °C	2 HOURS.	0 TO +12% OF INITIAL VALUE	TABLE 1 ON PAGE 13	WITHIN 12.5X ORIGINAL LIMIT			
7	SURGE TEST	<p>THE CAPACITOR SHALL BE SUBJECTED TO THE SURGE VOLTAGE AS SPECIFIED ON NEXT PAGE IN A CYCLE OF 6± 0.5 MIN. WHICH CONSISTS OF 30±5 SEC. FOLLOWED BY A DISCHARGE PERIOD OF APPROX. 5 MIN 30 SEC. AT A TEMPERATURE OF +85°C FOR 1,000 CYCLES.</p> <p>AND THE CAPACITOR SHALL BE STORED UNDER STANDARD ATMOSPHERIC CONDITIONS TO OBTAIN THERMAL EQUILIBRIUM AFTER MEASUREMENT.</p> <p><u>MEASURING CIRCUIT</u></p>								
										
		<p>WHERE</p> <p>R1 : PROTECTIVE SERIES RESISTOR (33Ω)</p> <p>R2 : DISCHARGE RESISTOR(33Ω)</p> <p>Cx : TEST CAPACITOR</p> <p>V : DC VOLTAGE</p> <p>S : SWITCH</p>								
		RATED VOLTAGE	2.5V	4V	6.3V	10V	16V	20V	25V	35V
		SURGE VOLTAGE	3.1V	5V	8V	13V	20V	26V	32V	45V

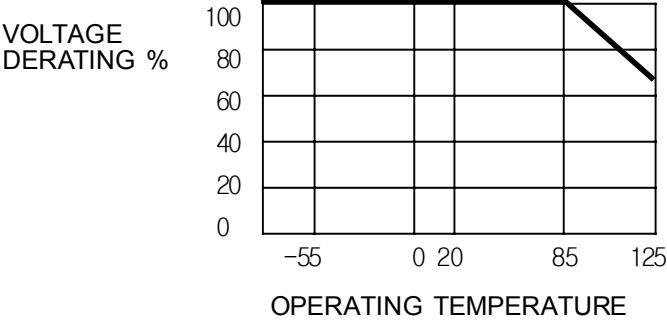
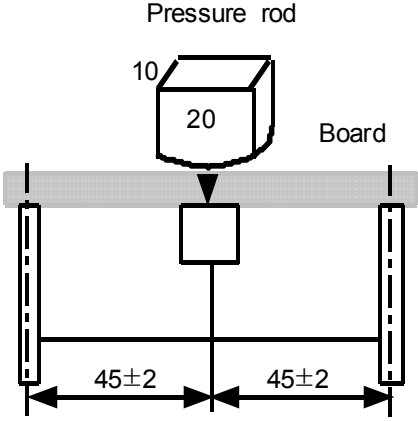
NO	ITEMS	TEST CONDITION	PERFORMANCE
8	DERATING VOLTAGE	<p>WHEN OPERATING AT HIGH TEMPERATURE RANGE FROM 85°C to 125°C, THE OPERATION SHALL BE CARRIED OUT AT A DERATED VOLTAGE OR LESS DERATING VOLTAGE <math>V_t</math> AT ANY TEMPERATURE BETWEEN 85°C AND 125°C SHALL BE CALCULATED BY THE FOLLOWING EQUATION</p> <div style="text-align: center;">  <p>VOLTAGE DERATING %</p> <p>OPERATING TEMPERATURE</p> <math display="block">= V_r - \frac{V_r - V_d}{40}(T - 85)</math> </div> <p>WHERE <math>V_t</math> : DERATED VOLTAGE AT ANY TEMP. BETWEEN 85°C to 125°C  <math>V_r</math> : RATED VOLTAGE  <math>V_d</math> : DERATED VOLTAGE AT 125°C</p>	
9	ELECTRODE (TERMINAL STRENGTH)	<p>APPLY PRESSURE IN THE DIRECTION OF THE ARROW AT A RATE OF ABOUT 0.5MM/SEC. UNTIL IT REACHES A BENT WIDTH OF 3MM AND HOLD FOR 30 SEC. THE TEST BOARD SHALL BE <b>IEC 40(S) 541</b>. FOR OTHER PROCEDURES REFER TO <b>IEC 40(S) 541</b>.</p> <div style="text-align: center;">  <p>Pressure rod</p> <p>10 20</p> <p>Board</p> <p>45±2    45±2</p> </div>	<p>THERE SHALL BE NO EVIDENCE OF MECHANICAL DAMAGE. ELECTRICAL CHARACTERISTICS SHALL SATISFY THE INITIAL REQUIREMENT. IF THERE ARE ELECTRODES ON BOTH SURFACES, IT SHALL SATISFY THE ABOVE REQUIREMENT ON WHICHEVER SURFACE IT MAY BE FIXATED ON.</p>

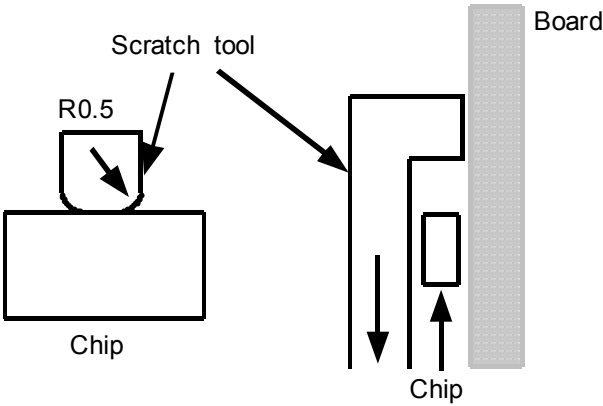
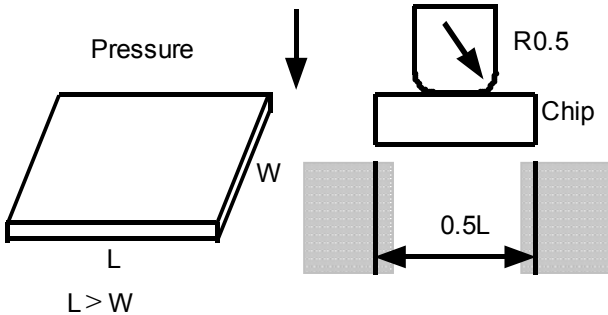

NO	ITEMS	TEST CONDITION	PERFORMANCE
10	ADHESION (ELECTRODE PEELING STRENGTH)	<p>A STATIC LAOD OF 19.6N USING A R0.5 SCRATCH TOLL SHALL BE APPLIED ON THE CORE OF THE COMPONENT AND IN THE DIRECTION OF THE ARROW AND HOLD FOR 5 SEC. THE TEST BOARD SHALL BE <b>IEC 40(S)541</b>. HOWEVER THE BASE MATERIAL SHALL BE G-10 or FR-4 (ANSI GRADE)</p> 	THERE SHALL BE NO EVIDENCE OF MECHANICAL DAMAGE. ELECTRICAL CHARACTERISTICS SHALL SATISFY THE INITIAL REQUIREMENT. IF THERE ARE ELECTRODES ON BOTH SURFACES, IT SHALL SATISFY THE ABOVE REQUIREMENT ON WHICHEVER SURFACE IT MAY BE FIXATED ON.
11	CORE BODY STRENGTH	<p>A ROD OF 9.8N USING A R0.5 PRESSURE ROD SHALL BE APPLIED TH THE CENTER IN THE DIRECTION OF THE ARROW AND HOLD FOR 10 SEC</p> 	THERE SHALL BE NO EVIDENCE OF MECHANICAL DAMAGE. ELECTRICAL CHARACTERISTICS SHALL SATISFY THE INITIAL REQUIREMENT.

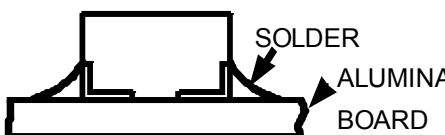
NO	ITEMS	TEST CONDITION	PERFORMANCE
12	SOLDERABILITY [Pb-free]	SOLDER TEMPERATURE : 245±5℃ DIP TIME : 3±0.5 SEC. SOLDER : Sn-3Ag-0.5Cu FLUX : ROSIN(KSM2951)+Solvent(ISA) (ROSIN 25WT%)	MORE THAN 95% OF THE TERMINAL SURFACE MUST BE SOLDERED NEWLY.
13	RESISTANCE TO SOLDERING HEAT	PREHEAT : 100~110℃ FOR 30 SEC. TEMPERATURE : 260±5℃ DIP TIME : 10 ±1 SEC  ALL SAMPLES SHALL BE DIPPED IN SOLDER BATH. MEASUREMENT SHALL BE MADE AT ROOM TEMPERATURE AFTER 1~2 HOURS OF COOLING TIME.	CHANGE IN CAPACITANCE : ±5% OF INITIAL VALUE TANGENT OF LOSS ANGLE : LEAKAGE CURRENT : APPEARANCE : THERE SHALL BE NO EVIDENCE OF MECHANICAL DAMAGE. .
		<u>CONVECTION REFLOW</u> PREHEAT : 150~190℃ FOR 130 SEC. PEAK TEMPERATURE : 260±5℃ FOR 10 SEC. METHOD : SAMPLES SHALL BE PASSED REFLOW 3 TIMES. MEASUREMENT SHALL BE MADE AT ROOM TEMPERATURE AFTER 3~4 HOURS OF COOLING TIME.	Change in capacitance: ±10% of initial value Tangent of loss angle:  Leakage Current :
14	RESISTANCE TO CLEAN TEST	<u>IMMERSION CLEANING</u> THE CAPACITOR SHALL BE CLEANED AT ROOM TEMPERATURE FOR 60sec. USING ISOPROPYL ALCOHOL	THERE SHALL BE NO EVIDENCE OF MECHANICAL DAMAGE. AND MARKING SHALL BE LEGIBLE. ELECTRICAL CHARACTERISTICS SHALL SATISFY THE INITIAL REQUIREMENT.
15	VIBRATION	FREQUENCY : 10 to 55 to 10Hz (in 1 min.) MAX AMPLITUDE : 1.5 mm. DIRECTION OF VIBRATION : IN DIRECTION OF X,Y AND Z AXES TIME : 2 HOURS EACH DIRECTION AND 6 HOURS IN TOTAL DURING THE LAST 30 min. OF VIBRATION IN EACH DIRECTION, THE CAPACITANCE SHALL BE MEASURED 3 TO 5 TIMES. FOR OTHER PROCEDURES REFER TO IEC Pub. 68-2-6.  <u>MOUNTING METHOD</u> 	CHANGE IN CAPACITANCE : WITHIN : ±5% OF THE INITIAL VALUE TANGENT OF LOSS ANGLE :  LEAKAGE CURRENT :  APPEARANCE : THERE SHALL BE NO EVIDENCE OF MECHANICAL DAMAGE. .

NO	ITEMS	TEST CONDITION			PERFORMANCE
16	MOISTURE RESISTANCE	THE CAPACITOR SHALL BE STORED AT A TEMPERATURE OF $40 \pm 2^\circ\text{C}$ AND RELATIVE HUMIDITY OF 90% TO 95% FOR $500 \pm 8$ HOURS. ELECTRICAL MEASUREMENTS SHALL BE MADE AFTER BEING BOARD AT ROOM TEMPERATURE FOR 1~2 HOURS. FOR OTHER PROCEDURES REFER TO IEC Pub. 68-2-2.			CHANGE IN CAPACITANCE : WITHIN : $\pm 10\%$ OF THE INITIAL VALUE TANGENT OF LOSS ANGLE : LEAKAGE CURRENT :
17	LOAD LIFE				CHANGE IN CAPACITANCE : WITHIN : $\pm 10\%$ OF THE INITIAL VALUE TANGENT OF LOSS ANGLE : LEAKAGE CURRENT :
		TEMPERATURE	VOLTAGE	TIME	
		85 °C	RATED VOLTAGE	2,000 HOURS	
		125 °C	DERATED VOLTAGE	2,000 HOURS	
		THE CAPACITOR SHALL BE PLACED IN A CIRCULATING AIR OVEN AT AN AMBIENT. ELECTRICAL MEASUREMENTS SHALL BE MADE AFTER BEING STORED AT ROOM TEMPERATURE FOR 1~2 HOURS.			
18	STORAGE AT LOW TEMPERATURE	THE CAPACITOR SHALL BE STORED AT A TEMPERATURE OF $-55 \pm 2^\circ\text{C}$ FOR $240 \pm 8$ HOURS WITHOUT LOAD. ELECTRICAL MEASUREMENTS SHALL BE MADE AFTER BEING STORED AT ROOM TEMPERATURE FOR 1~2 HOURS			ELECTRICAL CHARACTERISTICS SHALL SATISFY THE INITIAL REQUIREMENT.
19	Thermal Shock				CHANGE IN CAPACITANCE : WITHIN : $\pm 10\%$ OF THE INITIAL VALUE TANGENT OF LOSS ANGLE : LEAKAGE CURRENT :
		STEP	TEMPERATURE	TIME	
		1	$-55 \begin{smallmatrix} 0 \\ -3 \end{smallmatrix} ^\circ\text{C}$	30 $\pm 3$ MIN	
		2	$25 \pm 5^\circ\text{C}$	15 $\pm 2$ MIN	
		3	$125 \begin{smallmatrix} 0 \\ -3 \end{smallmatrix} ^\circ\text{C}$	30 $\pm 3$ MIN	
		4	$25 \pm 5^\circ\text{C}$	15 $\pm 2$ MIN	
		THE CAPACITOR SHALL BE SUBJECTED TO EACH SPECIFIED TEMPERATURE FOR EACH SPECIFIED TIME IN THE TABLE ABOVE THESE 4 STEP CONSTITUTES ONE CYCLES SHALL BE PERFORMED CONTINUOUSLY			

## PACKAGING

### ● MARKING

#### ▶ A CASE

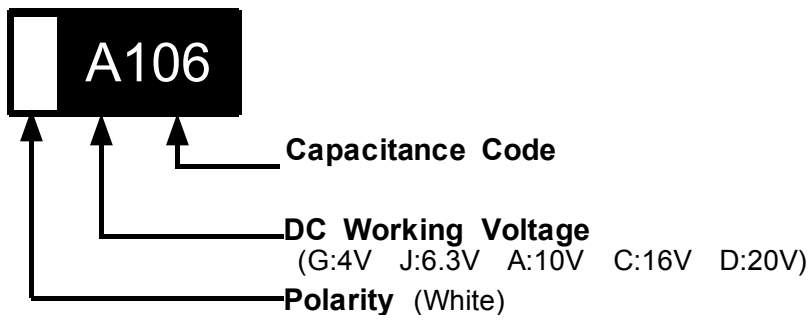

#### ▶ B CASE

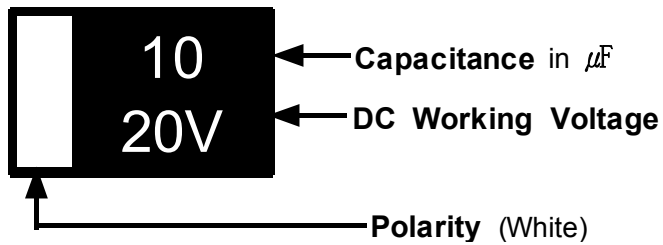

#### ▶ C,D CASE

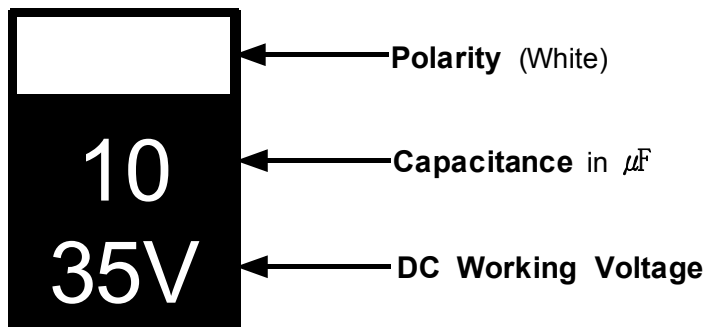

► P CASE

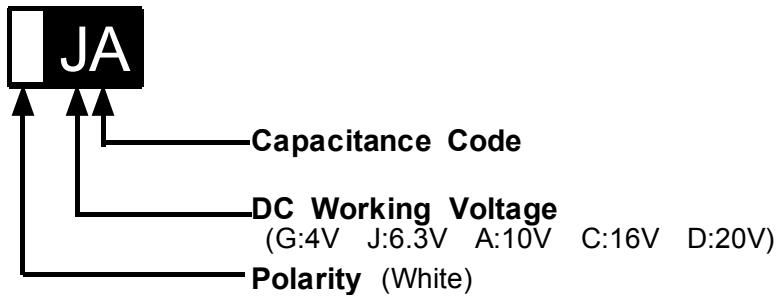

Capacitance Range	1 DIGIT	2 DIGIT
$< 1.0 \mu F$	A Small Letter	A Small Letter
$1.0 \mu F \leq \text{Cap.} < 10 \mu F$	A Capital Letter	A Small Letter
$\geq 10 \mu F$	A Capital Letter	A Capital Letter

**【Code Reference】**

$\mu F \backslash V$	4	6.3	10	16	20
0.22	gj	jj	aj	cj	
0.33					
0.47	gs	js	as	cs	ds
0.68	gw	jw	aw	cw	dw
1.0	Ga	Ja	Aa	Ca	
1.5					
2.2	Gj	Jj	Aj	Cj	
3.3	Gn	Jn	An		
4.7	Gs	Js	As	Cs	
6.8	Gw	Jw			
10	GA	JA	AA		
15					
22	GJ	JJ			

## ● EMBOSSED PLASTIC TAPE

The tantalum chip capacitors shall be packaged in tape and reel form for effective use.

- Tape : Semitransparent embossed plastic
- Cover tape : Attached with press, polyester
- The tension of removing the cover tape,  $F=10 \sim 70g$

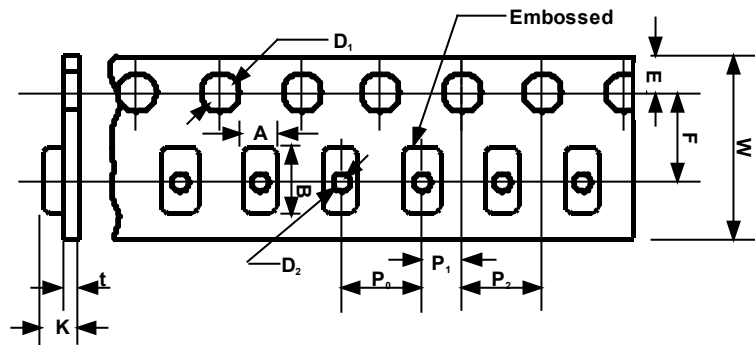
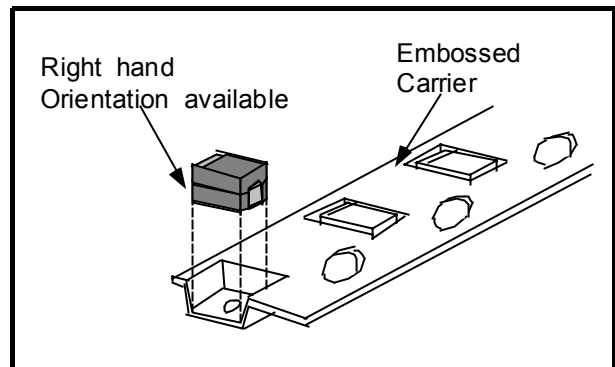

Case Code	$W \pm 0.3$ ( $\pm 0.012$ )	$F \pm 0.1$ ( $\pm 0.004$ )	$E \pm 0.1$ ( $\pm 0.004$ )	$P_0 \pm 0.1$ ( $\pm 0.004$ )	$P_1 \pm 0.1$ ( $\pm 0.004$ )	$P_2 \pm 0.1$ ( $\pm 0.004$ )	$D_1 + 0.1$ ( $+0.004$ )	$D_2$ Min.	t	$A \pm 0.2$ ( $\pm 0.008$ )	$B \pm 0.2$ ( $\pm 0.008$ )	$K \pm 0.2$ ( $\pm 0.008$ )
J*	8 (0.315)	3.5 (0.138)	1.75 (0.069)	4 (0.157)	2 (0.079)	4 (0.157)	$\phi 1.5$ (0.059)	$\phi 0.6$ (0.024)	0.25 (0.0098)	0.98 (0.039)	1.80 (0.071)	1.0 (0.039)
P*										1.4 (0.055)	2.3 (0.091)	1.4 (0.055)
A										1.9 (0.075)	3.5 (0.138)	1.9 (0.075)
B										3.3 (0.130)	3.8 (0.150)	2.1 (0.083)
C	12 (0.472)	5.5 (0.217)	8 (0.315)	8 (0.315)	8 (0.315)	8 (0.315)	$\phi 1.5$ (0.059)	$\phi 1.5$ (0.059)	0.3 (0.012)	3.7 (0.146)	6.4 (0.252)	3.0 (0.118)
D										4.8 (0.189)	7.7 (0.303)	3.3 (0.130)

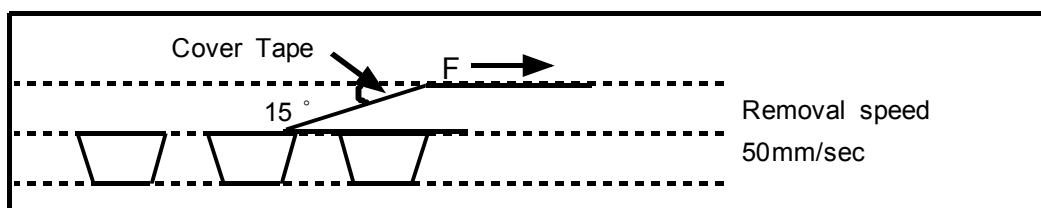

● REEL DIMENSION

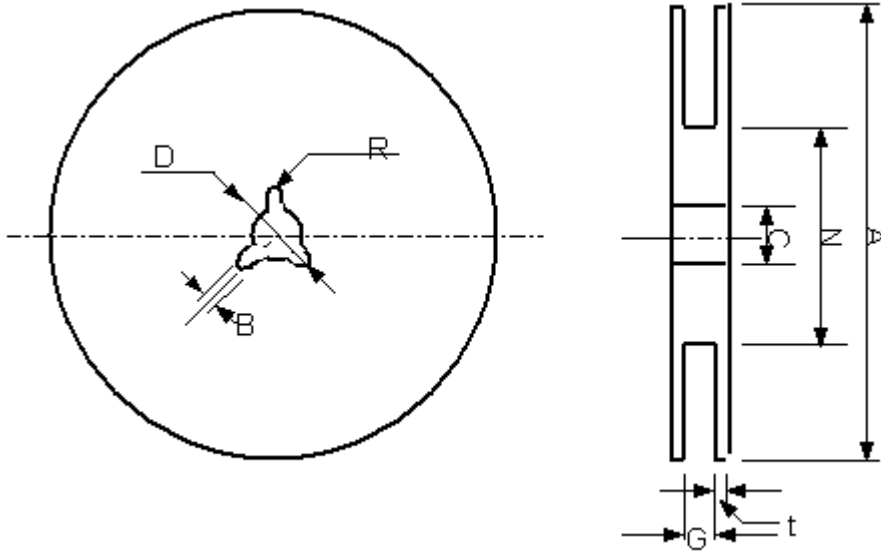

Tape Width	A±2 (±0.079)	N Min.	C±0.5 (±0.020)	D±0.5 (±0.020)	B±0.51 (±0.020)		t±0.5 (±0.020)	R
8mm	ø178 (7)	ø70 (2.756)	ø13 (0.512)	ø21 (0.827)	2 (0.079)	10 (0.394)	2 (0.079)	0.99 (0.039)
12mm		ø60 (2.362)				14 (0.551)		
8mm	ø330 (13)	ø80 (3.150)	ø13 (0.512)	ø21 (0.827)	2 (0.079)	10 (0.394)	2 (0.079)	0.99 (0.039)
12mm						14 (0.551)		

Case Size reference	180mm(7") reel	330mm(13") reel
J	4,000pcs	-
P	3,000pcs	-
A , B	2,000pcs	8,000pcs
C , D	500pcs	2,500pcs

## APPLICATION MANUAL

The operational attentions to the use of the tantalum capacitors are as follows:

- Electrical
- Environmental
- Conditions for mounting on equipment and circuit boards
- Mechanical vibration, shock

If the tantalum capacitors are used without satisfying any one of these conditions, the probability of short-circuiting, leakage current, ignition or other problems to occur increases. To avoid such problems, observe the following precautions when using the tantalum capacitors.

### ● OPERATING VOLTAGE

- ▶ The voltage derating factor should be as great as possible. Under normal conditions, the operating voltage should be reduced to 50% or less of the rating. It is recommended that the operating voltage be 30% or less of the rating, particularly when the tantalum capacitors are used in a low-impedance circuit (see Figs. 1, 2, and 3).
- ▶ For circuits in which a switching, charging, discharging, or other momentary current flows, it is recommended that the operating voltage be 30% or less of the rating, with a resistor connected in series to limit the current to 300 mA or less.
- ▶ When the tantalum capacitors are to be used at an ambient temperature of higher than 85°C, the recommended operating range shown in Fig. 3 should not be exceeded.

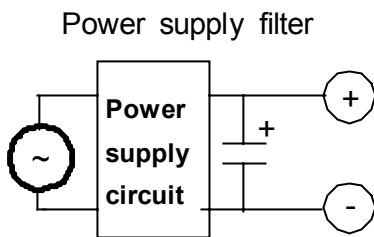

Fig. 1

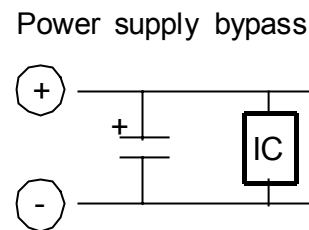

Fig. 2

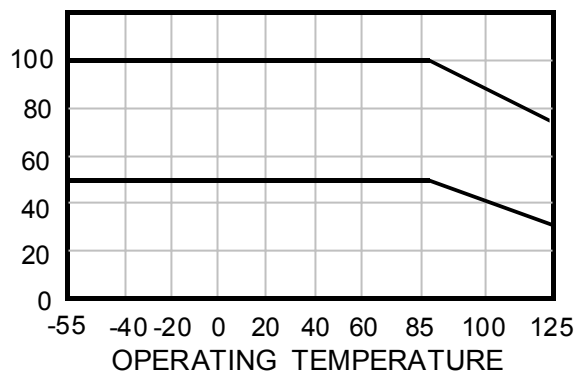

Fig. 3



## ● RIPPLE

The maximum permissible ripple voltage and current are related to the ratings case size.

Please consult us detail in formations.

### ► Ripple Current

The maximum permissible ripple current,  $I_{MAX}$ , is calculated as follows :

$$I_{MAX} = \sqrt{\frac{P_{MAX}}{ESR(f)}}$$

where:

$I_{MAX}$  : Maximum permissible capacitor ripple current (Arms).

$P_{MAX}$  : Maximum permissible capacitor power loss (W).

Varies with the ambient temperature and case size.

Calculated according to Table

$ESR(f)$ : Capacitor equivalent series resistance ( $\Omega$ ).

Since the  $ESR(f)$  value varies with the ripple frequency, however, the following correction must be made in accordance with the operating frequency (see Fig. 4).

$$ESR(f) = K \cdot ESR(120)$$

K : Coefficient for the operating frequency (Fig. 4).

$$ESR(120) = \tan \delta \cdot X_c = \frac{\tan \delta}{2\pi f C}$$

where:

$ESR(120)$  : Equivalent series resistance at 120 Hz ( $\Omega$ ).

$X_c$  : Capacitive reactance at 120 Hz ( $\Omega$ ).

C : Electrostatic capacitance at 120 Hz ( $\mu F$ ).

f : Operating frequency (Hz).

Table.1 Maximum permissible power loss values ( $P_{MAX}$ ) by case size

Ambient temperature (°C)	$P_{MAX}(W)$					
	J	P	A	B	C	D
25	0.015	0.015	0.030	0.030	0.030	0.050
55	0.010	0.010	0.019	0.019	0.019	0.032
85	0.005	0.005	0.010	0.010	0.010	0.018

Table.2 Hz VS K

Frequency	K
120	1.0
400	0.8
1k	0.65
10k	0.50
20k	0.45
40k	0.43
100k	0.40
1M	0.35

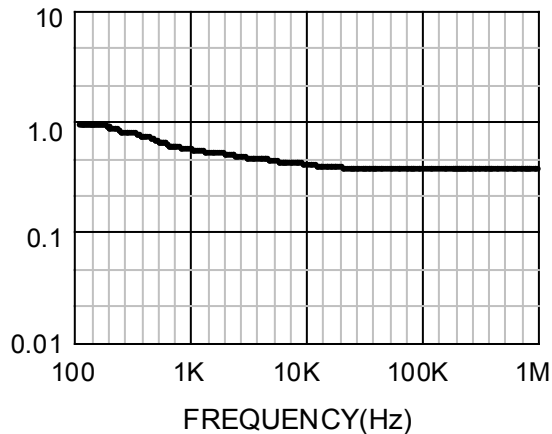

Fig.4 Correction Coefficient(K)

### ► Ripple Voltage

If an excessive ripple voltage is applied to the tantalum capacitors, their internal temperature rises due to Joule heat, resulting in the detriment of their reliability.

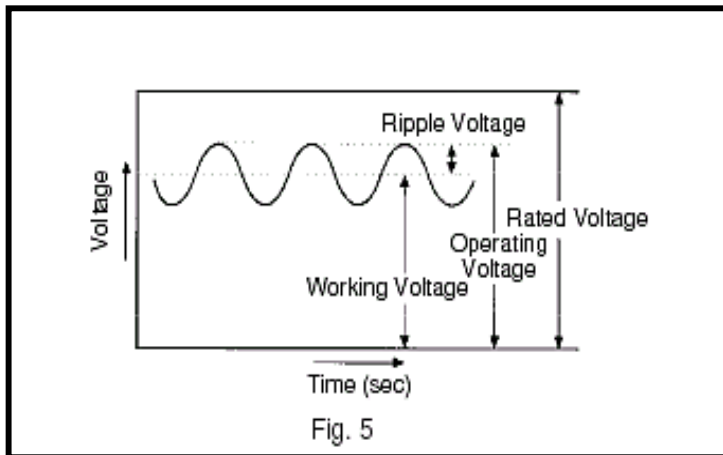

Fig. 5

- ▷ The tantalum capacitors must be used in such a conditions that the sum of the Working Voltage and ripple voltage peak values does not exceed the rated voltage (Fig. 5)
- ▷ Ensure that an reverse voltage due to superimposed voltages is not applied to the capacitors.
- ▷ The maximum permissible ripple voltage varies with the rated voltage. Ensure that ripple voltage does not exceed the values shown in Figs 6 and 7. If, however, the capacitors are used at a high temperature, the maximum permissible ripple voltage must be calculated as follows:

$$V_{rms}(at\ 55^{\circ}C) = 0.7 \times V_{rms}(at\ 25^{\circ}C)$$

$$V_{rms}(at\ 85^{\circ}C) = 0.5 \times V_{rms}(at\ 25^{\circ}C)$$

$$V_{rms}(at\ 125^{\circ}C) = 0.3 \times V_{rms}(at\ 25^{\circ}C)$$

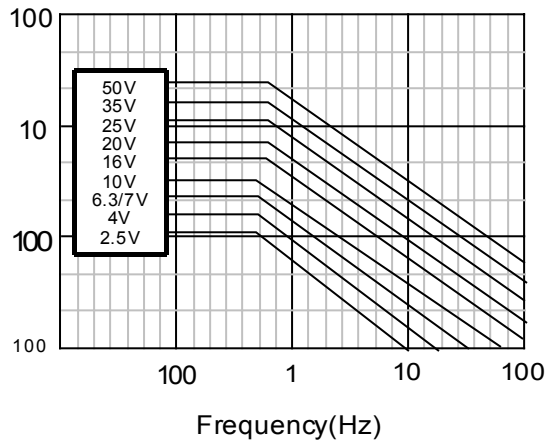

Fig.6 Maximum permissible ripple voltage (P,A,B)

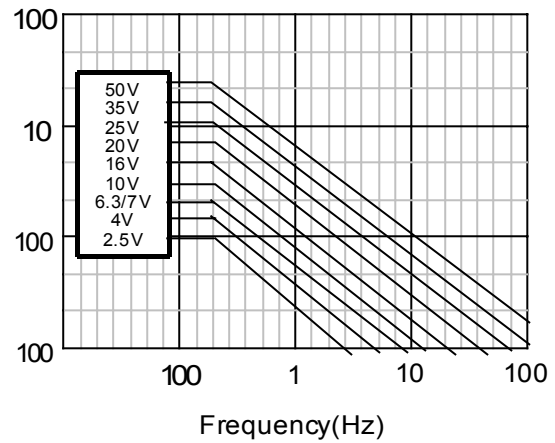

Fig.7 Maximum permissible ripple voltage (C,D)

## ● REVERSE VOLTAGE

Solid tantalum capacitors are polarized device and may be permanently damaged or destroyed, if connected with the wrong polarity.

- ▷ The tantalum capacitors must not be operated and changed in reverse mode. And also the capacitors must not be used in an only AC circuit.
- ▷ The tantalum capacitor dielectric has a rectifying characteristics. Therefore, when a reverse voltage is applied to it, a large current flows even at a low reverse voltage. As a result, it may spontaneously generate heat and lead to shorting.
- ▷ Make sure that the polarity and voltage is correct when applying a multi-meter or similar testing instrument to the capacitors because a reverse voltage or overvoltage can be accidentally applied.
- ▷ When using the capacitors in a circuit in which a reverse voltage is applied, consult your local SAMSUNG ELECTRO-MECHANICS agent. If the application of an reverse voltage is unavoidable, it must not exceed the following values.

At 20°C: 10% of the rated voltage of 1 V, whichever smaller.

At 85°C: 5% of the rated voltage or 0.5 V, whichever smaller.

## ● RELIABILITY OF TANTALUM CAPACITORS

### ► General

The failure rate of the tantalum capacitor varies with the digression ratio, ambient temperature, circuit resistance, circuit application, etc.

Therefore, when proper selections are made so as to afford additional margins, higher reliability can be derived from the tantalum capacitors. Some examples of actual failure rates are presented below for your reference.

### ► Failure Rate Calculation Formula

The tantalum capacitors are designed to work at their basic failure rates shown in Table 3 that prevail when the rated voltage is applied for 1000 hours at 85°C.

Table 3 Basic failure rate

TYPE	Classification	Basic failure rate
SCE,SVE	Low ESR type	1%/1000h
SCM,SVM	Ultra-Miniaturization Type(0603)	
SCL	Low-profile Type	
SCS,SVS	Small Type	
SCN,SVN	Standard type	
PC*	Conductive Polymer Type	

### ▷ Failure rate calculation formula

$$\lambda_{use} = \lambda_{85} \times K_V \times K_R$$

$\lambda_{use}$  : Estimated capacitor failure rate under the operating conditions.

$\lambda_{85}$  : Basic failure rate (Table 3)

$K_V$  : Failure rate correction coefficient by the ambient temperature and derating factor.

$K_R$  : Failure rate correction coefficient by the circuit resistance,

which is the series-connected resistance divided by the voltage applied to the capacitor.

This resistance is connected in series when the power supply side is viewed from the capacitor side.

$K_{(derating\ factor)} = \text{operating voltage} / \text{rated voltage}$

## ● RELIABILITY PREDICTION

Solid tantalum capacitors exhibit no degradation failure mode during shelf storage and show a constantly decreasing failure rate (i.e., absence of wearout mechanism) during life tests. This failure rate is dependent upon three important application conditions: DC voltage, temperature, and circuit impedance.

Estimates of these respective effects are provided by the reliability nomograph. (Figure 8.)

The nomograph relates failure rate to voltage and temperature while the table relates failure rate to impedance. These estimates apply to steady-state DC condition, and they assume usage within all other rated conditions.

Standard conditions, which produce a unity failure rate factor, are rated voltage, +85°C, and 0.1 ohm-per-volt impedance.

While voltage and temperature are straight-forward, there is sometimes difficulty in determining impedance. What is required is the circuit impedance seen by the capacitor. If several capacitors are connected in parallel, the impedance seen by each is lowered by the source of energy stored in the other capacitors. Energy is similarly stored in series inductors.

Voltage "de-rating" is a common and useful approach to improved reliability. It can be pursued too far, however, when it leads to installation of higher voltage capacitors of much larger size.

It is possible to lose more via higher inherent failure rate than is gained by voltage derating. SAMSUNG typically recommends 50% derating, especially in low impedance circuits.

Failure rate is conventionally expressed in units of percent per thousand hours. As a sample calculation, suppose a particular batch of capacitors has a failure rate of 0.5% / Khr under standard conditions.

What would be the predicted failure rate at 0.7 times rated voltage, 60°C and 0.6Ω/V?

The nomograph gives a factor of  $7 \times 10^{-2}$  and the table gives a factor of 0.4.

The failure rate estimate is then :

$$0.5 \times 7 \times 10^{-2} \times 0.4 \\ = 1.4 \times 10^{-2} \text{ or } 0.014\%/\text{Khr}$$

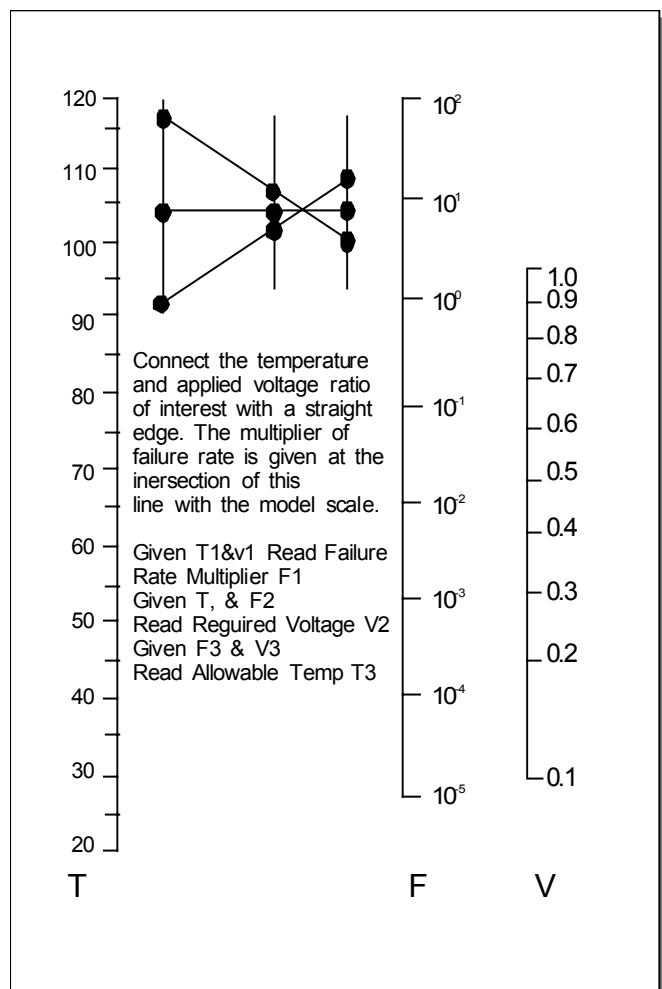

Fig.8 Reliability Nomograph

Table 4 Circuit Impedance Reliability Factors

Circuit Impedance (ohms/volt)	Failure Rate Impedance (multiplying factor)
0.1	1.0
0.2	0.8
0.4	0.6
0.6	0.4
0.8	0.3
1.0	0.2
2.0	0.1
3 or greater	0.07

## ● MOUNTING PRECAUTIONS

### ▶ Limit Pressure on Capacitor Installation with Mounter

A capacitor that has been damaged should be discarded to avoid later problems resulting from mechanical stress.

Pressure must not exceed 4.9 N with a tool end diameter of 1.5mm when applied to the capacitors using an absorber, centering tweezers, or the like. An excessively low absorber setting position would result in not only the application of undue force to the capacitors but capacitor and other component scattering, circuit board wiring breakage, and / or cracking as well, particularly when the capacitors are mounted together with other chips having a height of 1 mm or less.

### ▶ Flux

- ▷ Select a flux that contains a minimum of chlorine and amine.
- ▷ After flux use, the chlorine and amine in the flux remain and must therefore be removed.

### ▶ Recommended Soldering Pattern Dimensions

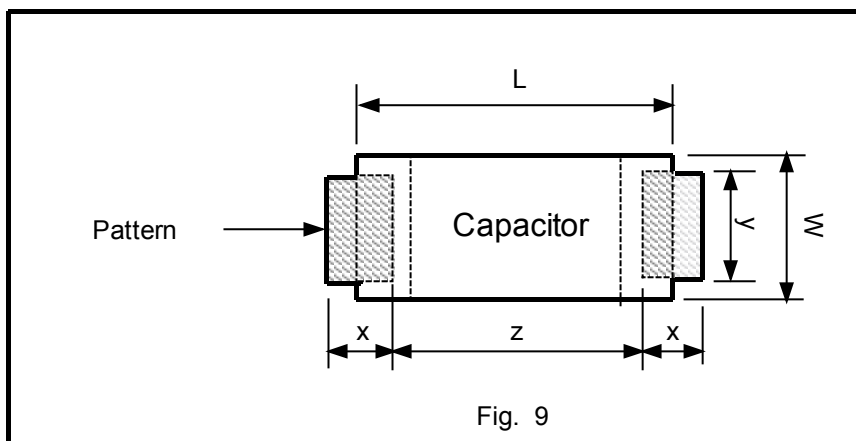

Table 4 Recommended soldering pattern dimensions(mm)

Dimensions Case	Capacitors size		Pattern dimensions		
	L	W	x	y	z
J	1.6	0.85	0.9	1.0	0.7
P	2.0	1.25	1.2	1.1	0.8
A	3.2	1.6	1.6	1.2	1.2
B	3.5	2.8	1.6	2.2	1.4
C	5.8	3.2	2.3	2.4	2.4
D	7.3	4.3	2.3	2.6	3.8

► **Chip Soldering Temperature and Time**

Capacitors are capable of withstanding the following soldering temperatures and conditions;

▷ Waved soldering

Capacitor body temperature : 230 °C ~ 260 °C

Time : 5 seconds or less

▷ Reflow soldering see figures

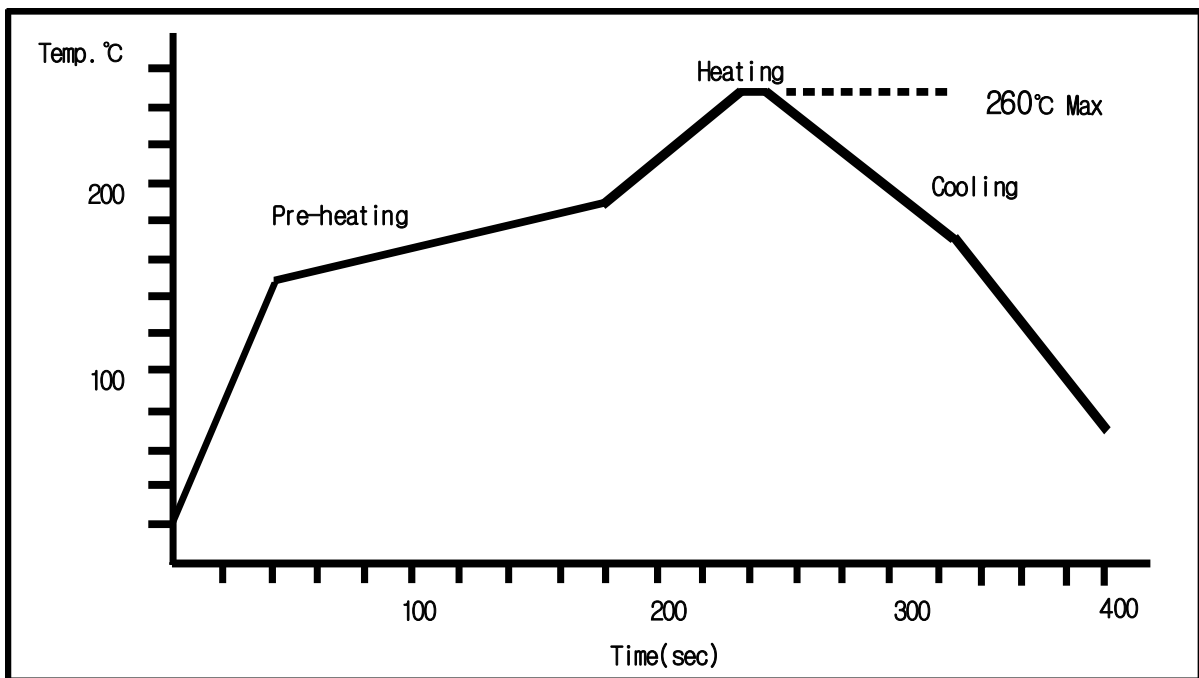

**Figure : Typical Temperature Profile of Reflow Soldering (pb-free)**

▷ Soldering with a soldering iron

The use of a soldering iron should be avoided wherever possible. If it is unavoidable, follow the instructions set forth in Table 5. The time of soldering with an iron should be one.

Table 5

<b>Soldering-iron tip temperature</b>	350°C <sub>MAX</sub>
<b>Time</b>	3 sec <sub>MAX</sub>
<b>Soldering-iron power</b>	30 W <sub>MAX</sub>

▶ **Cleaning after Mounting**

The following solvents are usable when cleaning the capacitors after mounting. Never use a highly active solvent.

- Halogen organic solvent (HCFC225, etc.)
- Alcoholic solvent (IPA, ethanol, etc.)
- Petroleum solvent, alkali saponifying agent, water, etc.

Circuit board cleaning must be conducted at a temperature of not higher than 50°C and for an immersion time of not longer than 30 minutes. When an ultrasonic cleaning method is used, cleaning must be conducted at a frequency of 48 kHz or lower, at an vibrator output of 0.02 W/cm<sup>3</sup>, at a temperature of not higher than 40°C, and for a time of 5 minutes or shorter.

NOTE 1: Care must be exercised in cleaning process so that the mounted capacitor will not come into contact with any cleaned object or the like or will not get rubbed by a stiff brush or the like. If such precautions are not taken particularly when the ultrasonic cleaning method is employed, terminal breakage may occur.

NOTE 2: When performing ultrasonic cleaning under conditions other than stated above, conduct adequate advance checkout.

● **OTHER**

- ▷ For further details, refer to EIAJ RCR-2368, Precautions and Guidelines for Using Electronic Device Tantalum Capacitors.
- ▷ If you have any questions, feel free to contact your local SAMSUNG ELECTRO-MECHANICS agent.