

HSF

NOTES:
 Rated Current:9.0A
 Rated Voltage:600V AC/DC
 Contact Resistance:20mΩ max
 Withstand Voltage:1500V AC/Minute
 Insulation Resistance:1000MΩ min
 Operation Temperature:-25°C to+85°C
 Insulator Material:High Temperature Plastic(UL94V-2)

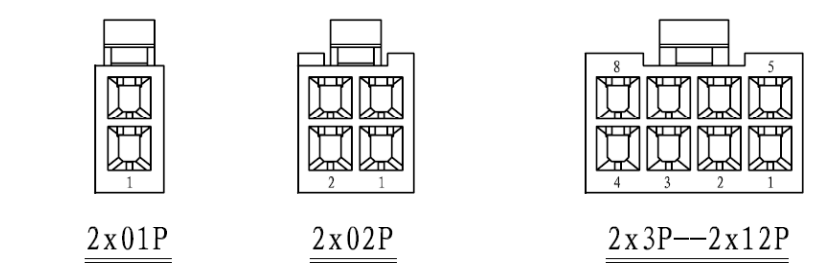
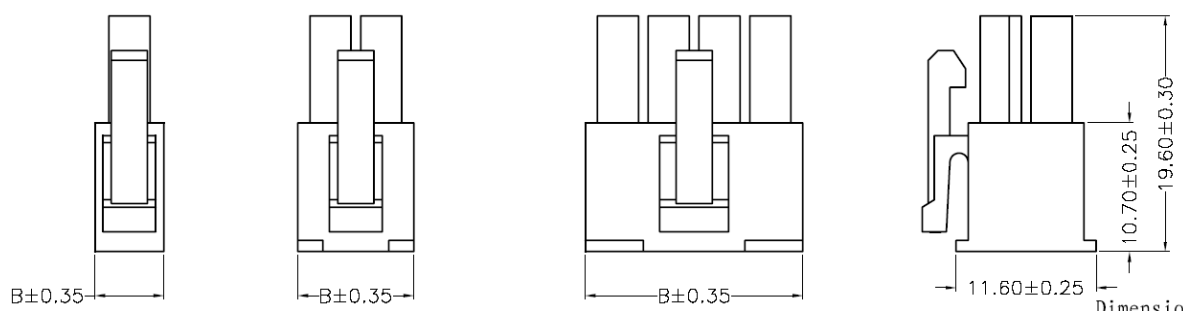
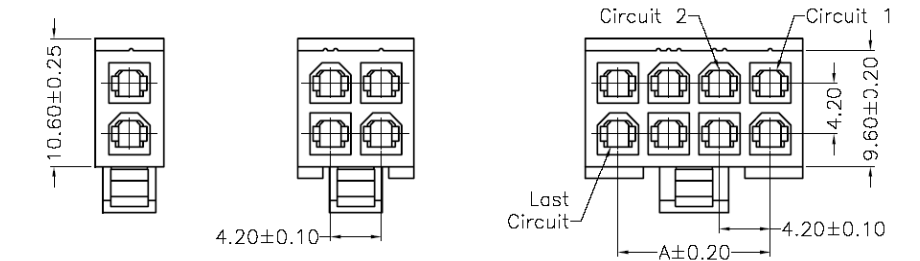

Dimensional & Ordering Information

Circuit	Part No.	Dimension	
		A	B
2x01	4201-02	4.20	5.70
2x02	4201-04	4.20	9.60
2x03	4201-06	8.40	13.80
2x04	4201-08	12.60	18.00
2x05	4201-10	16.80	22.20
2x06	4201-12	21.00	26.40
2x07	4201-14	25.20	30.60
2x08	4201-16	29.40	34.80
2x09	4201-18	33.60	39.00
2x10	4201-20	37.80	43.20
2x11	4201-22	42.00	47.40
2x12	4201-24	46.20	51.60

				OPERATION	DRAW	WCIXD	08/08/04	SCALE	1:1	HO CHIEN www.hochien.com		
				X.X ±0.30	DESIGN			UNIT	mm			
				X.XX ±0.25		CHECK			SIZE	A4	PART NO.	SEE TAB
A0	08/08/04	NEW		X.XXX ±0.20	APPROVE				SHEET	1/1	TITLE:	4.20 HOUSING DUAL ROW
REV	DATE	MODIFICATION	DESCRIPTION	CHANGE		APPROVE	APPROVE		PROJ.	Customer NO.		

HSF

NOTES:
 Rated Current:9.0A
 Rated Voltage:600V AC/DC
 Contact Resistance:20mΩ max
 Withstand Voltage:1000V AC/Minute
 Insulation Resistance:1000MΩ min
 Operation Temperature:-25°C to+85°C

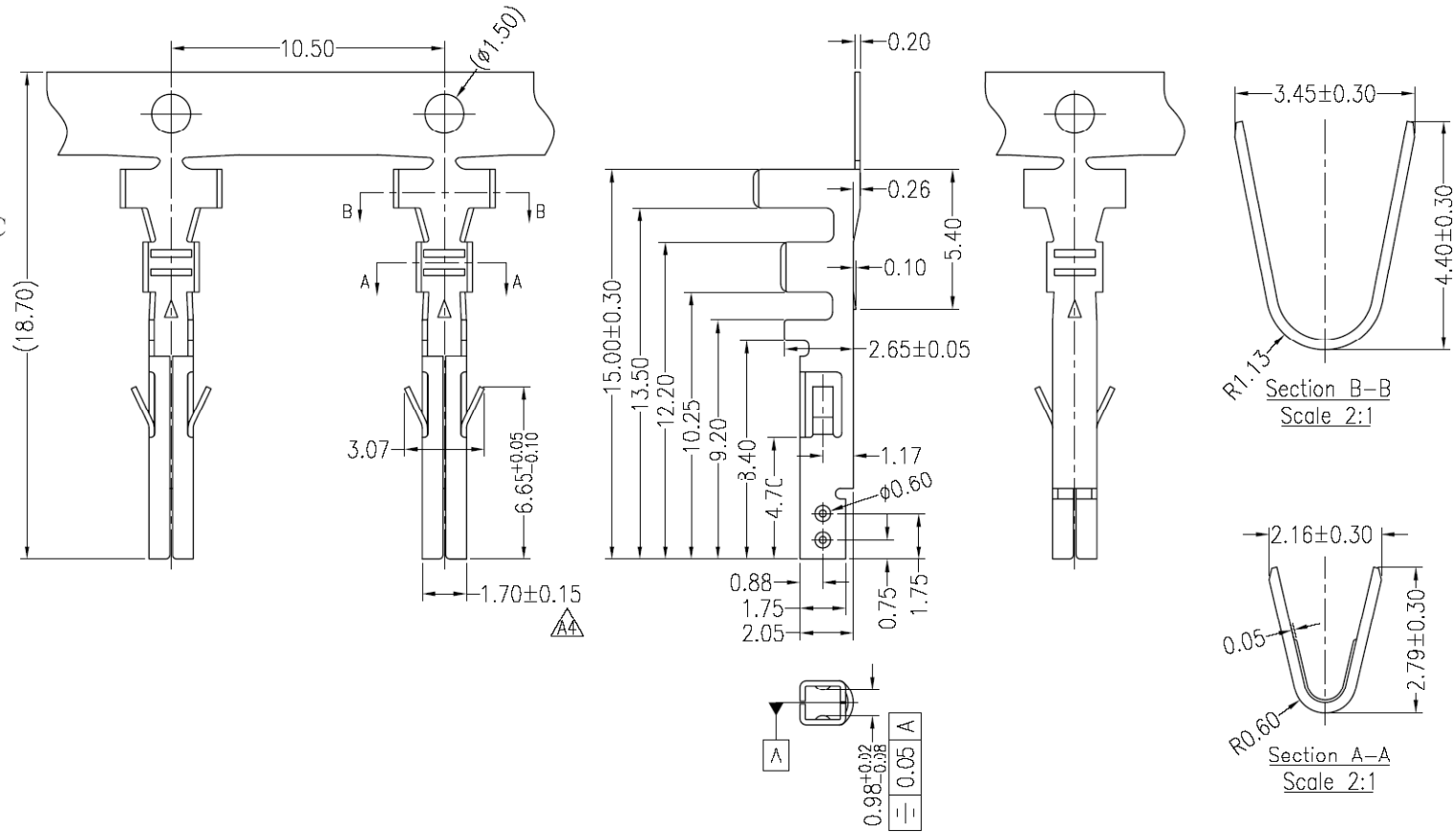

Dimensional & Ordering Information

Part No.	Thickness	Finish	Material	Wire Range	Insulation O.D	Q'ty/Reel
4201-10T	0.20	Tin-Plated	Phosphor bronze/Brass	AWG#18~#24	3.10mm(Max)	5,000pcs

REV	DATE	MODIFICATION DESCRIPTION	CHANGE	APPROVE	OPERATION	DRAW	Tang	10.07.20	SCALE	1:1	HO CHIEN www.hochien.com	
A4	10/07/20	Change The Dimension	_____	_____	X.X	±0.30	DESIGN		UNIT	mm	PART NO.	SEE TAB
A3	09/03/27	Change The Dimension	_____	_____	X.XX	±0.20	CHECK		SIZE	A4	TITLE:	4.20mm TERMINAL FEMALE
A2	09/02/12	Change The Dimension	_____	_____	X.XXX	±0.10	APPROVE		SHEET	1/1	CUSTOMER NO.	
					Angle	± 1'			PROJ.	☞		
					DIM	TOL						