

HSF

NOTES:
 Rated Current:2.0AMP.
 Contact Resistance:20mΩ Max.
 Withstand Voltage:500V AC/DC
 Insulation Resistance:1000MΩ Min.
 Operation Temperature:-40°C to +105°C

Contact Material:Brass
 Contact Plating:Au or Sn Over Ni
 Insulator Material:PA9T+30%G.F UL94V-0 BK

Recommended P.C.B Layout (Top Side)
 (PCB BOARD TOLERANCE±0.05)

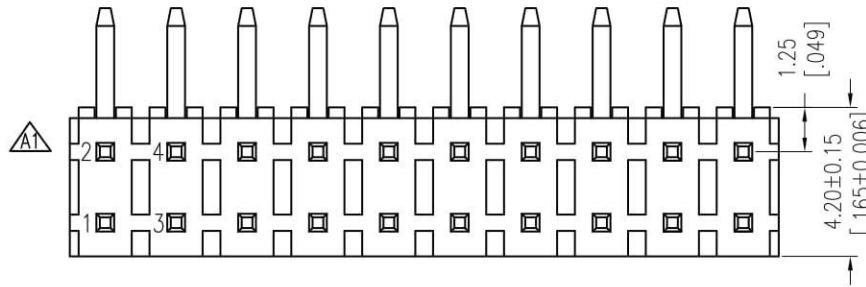
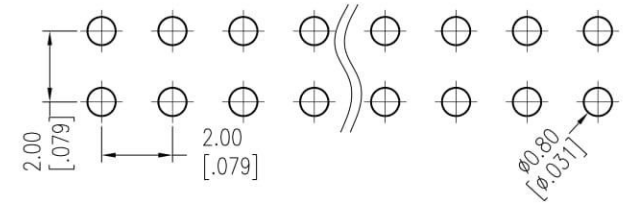

Ordering Information

2532A - 2X XX X

No. of Rows: 2
 No. of Pins 2-40: XX
 Contact Plating: G = Gold Flash, T = Gold/Flash Tin

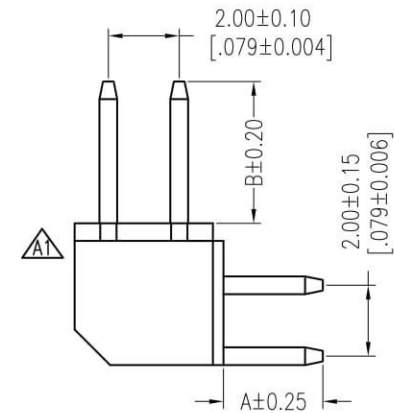
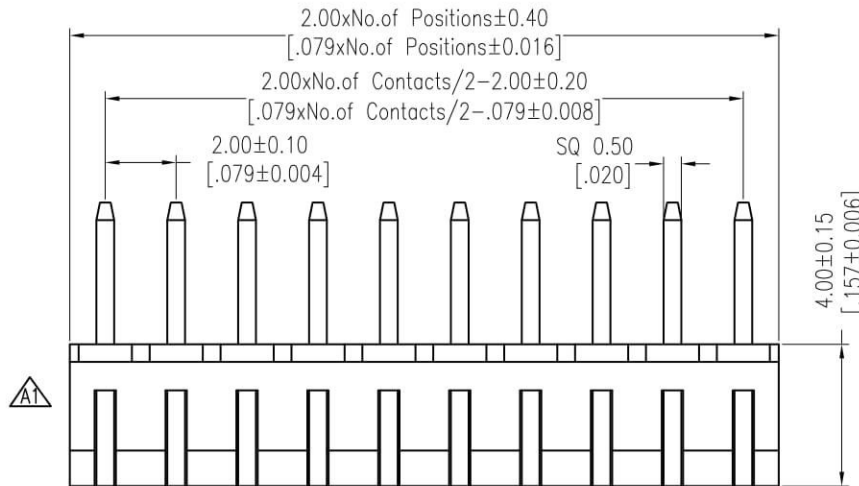

Item	Pin Length	A	B	Mating
Standard	9.50	2.80	4.00	
Alternate				

REV	DATE	MODIFICATION DESCRIPTION	CHANGE	OPERATION	DRAW	DATE	SCALE	Fit	PART NO.
A1	2014/01/16	Modify drawing	△	X.X ±0.40	CHECK	2014/01/16	UNIT mm		2523A-2XXXXX
A0	2012/04/26	NEW	-----	X.XX ±0.25			SIZE A4		TITLE: PH2.00 DUAL ROW 90° H=4.0
				X.XXX ±0.15			SHEET 1/1		Customer NO.
				Angle ± 3'	APPROVE		PROJ.		
				DIM TOL					

HO CHIEN
 www.hochien.com