

SPECIFICATION :

1. Electrical Char.

- Insulation Resistance : 500M-Ohm Min.
- Contact Resistance : 20milli-Ohm Max.
- Rating Current : 1.5A Max.
- Rating Voltage : 120V AC
- Dielectric Voltage : 1,000 Vrms 60 Sec. Min.

2. Physical char.

- Housing : PBT Glass Filled (UL 94V-0)
- Color : Black Color
- Spring Wire : 0.35mm Thickness Phosphor Bronze
Gold Plating Over Nickel.
- Temperature Range : - 25 /+90 Deg C
- Durability : 500 Mating cycles Min.

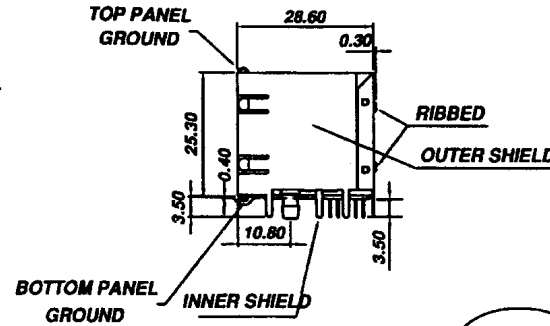
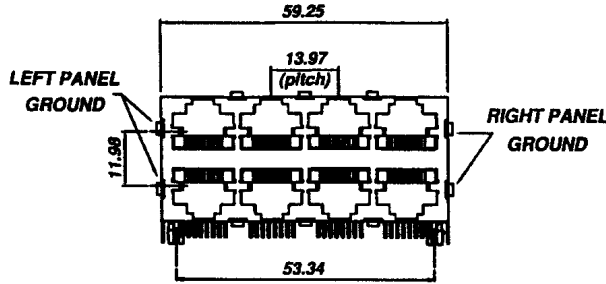

PANEL GROUND MODE

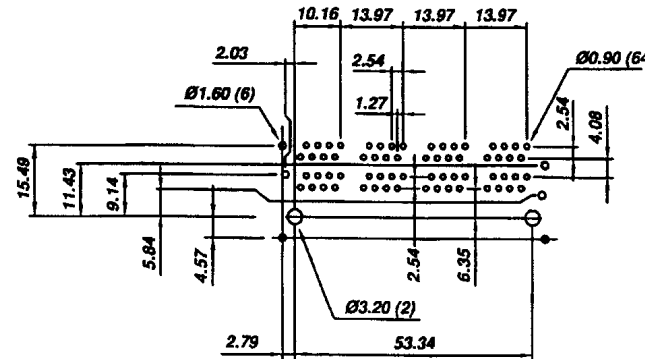
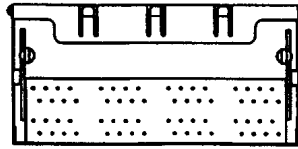

PCB LAYOUT
(Top View)

HC-600-24-F-X-B

F=8p8c

Gold plated 1=15u, 3=50u
2=30u, 4= 6 u

HO CHIEN

www.hochien.com

TITLE

DOUBLE DECK GANG PCB JACK
UL & cUL FILE NO. E131820

MODULAR JACKS ASSY FOR
HC-600-24-F-X-B

SCALE SIZE DWG. NO.9600 SERIES

NOT SCALED DRAWING	TOLERANCE UNLESS OTHERWISE NOTICE	INCH	MM	DR. Steven	DATE AUG-16 '04
THIRD ANGLE PROJECTION	LINEAR $\frac{MM}{INCH}$	00±0.01 000±0.005 0000±0.002	00±0.25 000±0.13 0000±0.05	CK'D Johnn	AUG-16 '04
MM INCH	ANGLE+0'30'	RADIL	+0.40 -0.15	APP'D Billy	AUG-16 '04

DWG. NO.

AS600022