

SPECIFICATION :

1. Electrical Char.

- Insulation Resistance : 500M-Ohm Min.
- Contact Resistance : 20milli-Ohm Max.
- Rating Current : 1.5A Max.
- Rating Voltage : 120V AC
- Dielectric Voltage : 1,000 Vrms 60 Sec. Min.

2. Physical char.

- Housing : PBT Glass Filled (UL 94V-0)
- Color : Black Color
- Spring Wire : 0.35mm Thickness Phosphor Bronze
Gold Plating Over Nickel.
- Temperature Range : - 25 /+90 Deg C
- Durability : 500 Mating cycles Min.

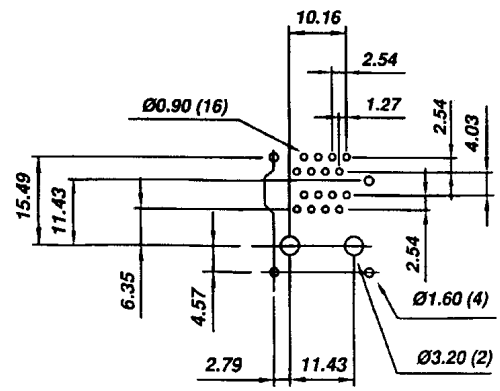
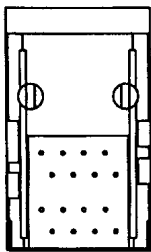

**PCB LAYOUT
(Top View)**

HC-600-21-F-X-D

F=8p8c

Gold plated	1=15u, 3=50u 2=30u, 4= 6 u
-------------	-------------------------------

HO CHIEN

www.hochien.com

TITLE

**DOUBLE DECK GANG PCB JACK
UL & cUL FILE NO. E131820**

**MODULAR JACKS ASSY FOR
HC-600-21-F-X-D**

SCALE SIZE DWG. NO.9600 SERIES

NOT SCALED DRAWING	TOLERANCE UNLESS OTHERWISE NOTICE	INCH	MM	DR.	DATE
 THIRD ANGLE PROJECTION	LINEAR $\frac{MM}{INCH}$	00±0.01	00±0.25	Steven	AUG-16 '04
		000±0.005	000±0.13	CK'D Johnn	AUG-16 '04
$\frac{MM}{INCH}$	ANGLE+0' 30'	RADIL	+0.40 -0.15	APP'D Billy	AUG-16 '04

DWG. NO. **AS600012**