

成型尺寸	公差
5mm以下	±0.3
5~20mm	±0.4
20~40mm	±0.5
40~60mm	±0.6
60~100mm	±0.8
100mm以上	±1.0

REVISIONS			
REV	DESCRIPTION	DATE	BY
E	SR4-10* 料號變更 SR4-10S	2003.09.02	LINDA
F	SR4-10S 插梢與SR4-10共用	2003.12.10	S.J.C.

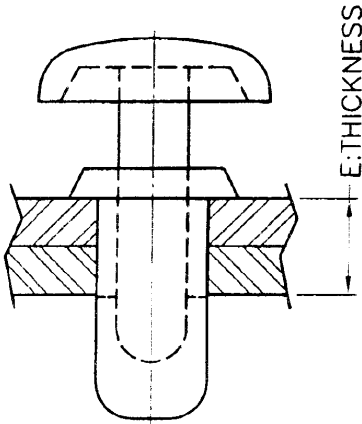
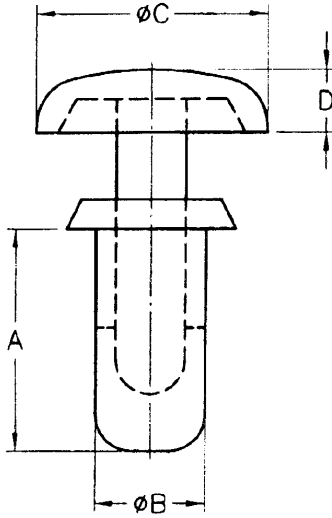

PART NO.	A	B	C	D	E	裝配孔徑
SR2.6-3.2	3.2	2.6	5.0	1.7	1.0~2.0	2.6~2.7
SR2.6-4.2	4.2	2.6	5.0	1.7	2.0~3.0	
SR2.6-4.8	4.8	2.6	5.0	1.4	2.5~3.4	
SR2.6-5.5	5.5	2.6	5.0	1.4	3.0~4.3	
SR2.6-7.2	7.2	2.6	5.0	1.4	3.0~4.3	
SR3-3.5	3.6	3.0	6.3	1.7	1.0~2.0	3.0~3.1
SR3-4.5	4.5	3.0	6.3	1.7	2.0~3.0	
SR3-5.5	5.5	3.0	6.3	1.7	3.0~4.0	
SR3-6	6	3.0	6.3	1.7	3.5~4.5	
SR3-6.5	6.5	3.0	6.3	1.7	4.0~5.0	
SR3-7.5	7.5	3.0	6.3	1.7	5.0~6.0	
SR3-8	8.1	3.0	6.3	1.7	5.5~6.5	
SR3-9	9.1	3.0	6.3	1.7	6.5~7.5	
SR3-10	10.0	3.0	6.3	1.7	7.5~8.5	
SR3-13	13.0	3.0	6.2	1.7	10.0~11.0	
SR3-15	15.5	3.0	6.2	1.7	11.5~13.0	
SR3.5-4.5	4.5	3.5	6.3	1.7	2.0~3.0	3.5~3.6
SR3.5-5	5.0	3.5	6.3	1.7	2.5~3.5	
SR3.5-5.5	5.5	3.5	6.3	1.7	3.0~4.0	
SR3.5-6	6.0	3.5	6.3	1.7	3.0~4.0	
SR3.5-7	7.0	3.5	6.3	1.7	4.5~5.5	
SR4-5	5.0	4.0	7.8	1.9	2.5~3.5	4.0~4.1
SR4-6	6.1	4.0	7.8	1.9	3.5~4.5	
SR4-7	7.1	4.0	8.0	2.0	4.5~5.5	
SR4-8	8.1	4.0	8.0	2.0	5.5~6.5	
SR4-9	9.0	4.0	8.0	2.0	6.5~7.5	
SR4-10	10.0	4.0	8.0	2.0	7.5~8.5	
SR4-10S	10.0	4.0	8.0	2.0	7.5~8.5	
SR4-12	12.0	4.0	8.0	2.0	9.5~10.5	
SR4-25	24.5	4.0	8.0	2.0	22~23	
SR5-4.5	4.6	5.0	8.9	2.2	1.5~2.5	5.0~5.1
SR5-5.5	5.5	5.0	8.9	2.2	2.5~3.5	
SR5-6.5	6.5	5.0	8.9	2.2	3.5~4.5	
SR5-7.5	7.5	5.0	8.9	2.2	4.5~5.5	
SR5-8.5	8.4	5.0	8.9	2.2	5.5~6.5	
SR6-6	6.0	6.0	12.0	2.5	2.5~4.0	6.0~6.1

HO CHIEN
www.hochien.com

TITLE	尼龍鉚釘	產品規格圖面
MATERIAL	NYLON 66 UL94V-2	DATE 2003.09.02
FINISH		DRAWN Linda
COLOR	BLACK	CHECK
UNLESS OTHERWISE SPECIFIED TOLERANCE	SEE ABOVE	APPROVED

PART NUMBER	SEE ABOVE	DRAWING NUMBER	SR-H
SIZE	A4	SCALE	NONE
UNIT	mm	REV	F