

PANEL GROUND MODE

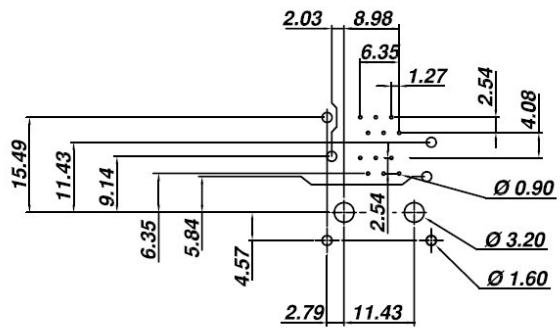

PCB LAYOUT
(Top View)

SPECIFICATION :

1. Electrical Char.

- Insulation Resistance : 500M-Ohm Min.
- Contact Resistance : 20milli-Ohm Max.
- Rating Current : 1.5A Max.
- Rating Voltage : 120V AC.
- Dielectric Voltage : 1,000 Vrms 60 Sec. Min.

2. Physical char.

- Housing : PBT Glass Filled (UL 94V-0)
- Color : Black Color
- Spring Wire : 0.35mm Thickness Phosphor Bronze
Gold Plating Over Nickel.
- Temperature Range : - 40°C / +85°C
- Durability : 500 Mating cycles Min.

HC-600-21-X-LXB

B=6p2c, C=6p4c
D=6p6c

Gold plated
1=15u, 3=50u
2=30u, 4= 6 u

HO CHIEN
www.hochien.com

TITLE
DOUBLE DECK GANG PCB JACK
UL & cUL FILE NO. E131820

MODULAR JACKS ASSY FOR
HC-600-21-X-LXB

SCALE SIZE DWG. NO.9600 SERIES

NOT SCALED DRAWING	TOLERANCE UNLESS OTHERWISE NOTICE	INCH	MM	DR. <i>Steven</i>	DATE JUN-22 '06
THIRD ANGLE PROJECTION	LINEAR MM INCH	00±0.01 000±0.005 0000±0.002	00±0.25 000±0.13 0000±0.05	CK'D <i>John</i>	JUN-22 '06
	ANGLE +0°30'	RADIL	+0.45 -0.15	APP'D <i>Billy</i>	JUN-22 '06

DWG. NO.
AS600026-1